

# Dead-weight tester High-pressure version Model CPB3800HP



WIKA data sheet CT 31.07

## Applications

- Primary standard for calibrating the pressure scale in a hydraulic range up to 2,600 bar
- Reference instrument for factory and calibration laboratories for the testing, adjustment and calibration of pressure measuring instruments
- Complete, stand-alone system, also suitable for on-site use

## Special features

- Total measurement uncertainty up to 0.007 % of reading
- Dual-range piston-cylinder system 2,600 bar with fully automated changing between ranges
- Factory calibration includes traceability to national standards, as standard, with UKAS calibration possible as an option
- Masses manufactured from stainless steel, can be adjusted to local gravity



Dead-weight tester, high-pressure version,  
model CPB3800HP

## Description

### Proven primary standard

Pressure balances (dead-weight testers) are the most accurate instruments available on the market for the calibration of electronic or mechanical pressure measuring instruments. The direct measurement of the pressure ( $p = F/A$ ), as well as the use of high-quality materials enable a very small measurement uncertainty, in conjunction with an excellent long-term stability.

The pressure balance (dead-weight tester) has therefore been used for years in factory and calibration laboratories in industry, national institutes and research laboratories.

### Stand-alone operation

Due to its integrated pressure generation and the pure mechanical measuring principle, the model CPB3800HP is ideal for on-site use for maintenance and service.

### Basic principle

Pressure is defined as the quotient of force and area. The core component of the CPB3800HP is therefore a very precisely manufactured piston-cylinder system, which is loaded with masses in order to generate the individual test points.

The masses applied are proportional to the target pressure and this is achieved through optimally graduated masses. As standard, these masses are manufactured to the standard gravity ( $9.80665 \text{ m/s}^2$ ), though they can be adjusted to a specific location and also UKAS calibrated.

## Easy operation

The integrated dual-area spindle pump enables rapid filling of the test system and smooth pressure generation up to 2,600 bar. At the same time, the precisely adjustable spindle pump also enables fine pressure adjustment. A control schematic for pressure generation on the instrument base facilitates quick and easy operation.

As soon as the measuring system reaches equilibrium, there is a balance of forces between the pressure and the mass load applied. The excellent quality of the system ensures that this pressure remains stable over several minutes, so that the pressure value for comparative measurements can be read without any problems, or also so that more complex adjustments can be carried out on the test item.

## Compact instrument design

The CPB3800HP is also particularly notable for its compact dimensions, which are not altered during operation, since the spindle runs within the pump body.

With its compact dimensions, the exceptionally robust ABS plastic case and the low weight associated with these, the CPB3800HP is also particularly suited for on-site applications.

The test item connection is equipped with a G ½ union nut with metal cone. M16 x 1.5, M20 x 1.5 und 9/16-18 UNF thread adapters with male threads are included in the scope of delivery.

## The piston-cylinder system

### High accuracy over a wide measuring range

The dual-range piston-cylinder system offers two measuring ranges in one case with automatic measuring range switching from low-pressure to high-pressure pistons. This provides the user with an extremely flexible measuring instrument that can cover a wide measuring range with high accuracy, with only one piston-cylinder system and one mass set. Additionally two test points can automatically be achieved by the operator loading masses once.

The piston and cylinder are manufactured from hardened steel and tungsten carbide, respectively. This pairing of materials has very low pressure and temperature coefficients of expansion, which results in a very good linearity for the effective area and a very high accuracy.

Piston and cylinder are very well protected, against contact, impacts or contamination from outside, in a solid stainless-steel/hardened tool steel case. At the same time, overpressure protection is integrated, which prevents the piston from being forced out vertically and avoids damage to the piston-cylinder system in the event of mass removal under pressure.



Control schematic on the CPB3800HP instrument base

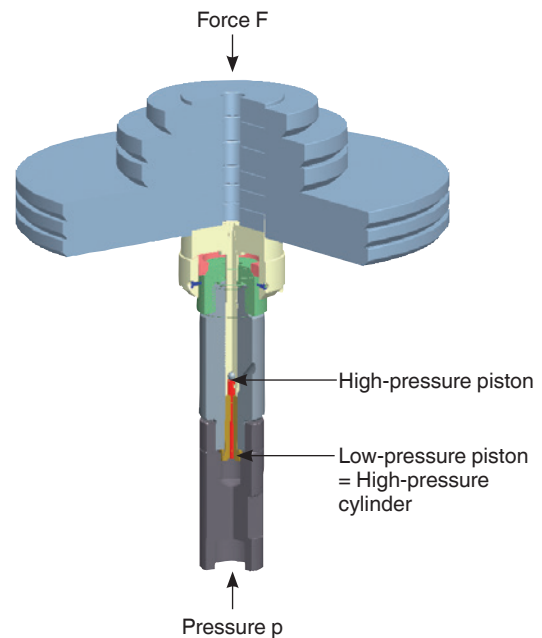

Dual-range piston-cylinder system 2,600 bar

The masses are stacked directly onto the piston-cylinder shaft. This makes it easier for the operator to place the masses on and thus enables a lower start value.

The overall design of the piston-cylinder system and the very precise manufacturing of both the piston and the cylinder, ensure exceptionally low friction force, which results in excellent operating characteristics with long free-rotation time and low sink rates. Thus a high long-term stability is ensured. Therefore the recommended recalibration interval is two to five years depending on the conditions of usage.

## Tables of masses

The following tables show, for the respective measuring range, the number of masses within a mass set, with their resulting nominal pressures.

The masses are manufactured, as standard, to the standard gravity ( $9.80665 \text{ m/s}^2$ ) although they can be adjusted for any particular location.

The relevant corrections should be made for example with the CPU6000 CalibratorUnit, see page 7, to ensure that the measuring system remains within specification (ambient temperature  $20 \text{ }^\circ\text{C}$ , atmospheric pressure  $1,013 \text{ mbar}$ , relative humidity  $40 \%$ ).

Measuring range	1 ... 2,600 bar		
	Quantity	1 ... 50 bar Nominal pressure per piece in bar	20 ... 2,600 bar Nominal pressure per piece in bar
Piston and make-up weight	1	1	20
Overhang (bell jar)	1	10	200
Masses (stackable on overhang (bell jar))	7	10	200
Masses (stackable on piston shaft)	3	10	200
	1	9	180
	1	5	100
	2	2	40
	1	1	20
	2	0.5	10
Set of fine increment masses (optional)	2	0.2	4
	1	0.1	2
	1	0.05	1
	2	0.02	0.4
	1	0.01	0.2

Measuring range	10 ... 40,000 psi or lb/in <sup>2</sup>		
	Quantity	10 ... 600 psi or lb/in <sup>2</sup> Nominal pressure per piece in psi or lb/in <sup>2</sup>	200 ... 40,000 psi or lb/in <sup>2</sup> Nominal pressure per piece in psi or lb/in <sup>2</sup>
Piston	1	10	200
Overhang (bell jar)	1	100	2,000
Masses (stackable on overhang (bell jar))	14	100	2,000
Masses (stackable on piston shaft)	4	100	2,000
	1	90	1,800
	1	50	1,000
	2	20	400
	1	10	200
	1	5	100
Set of fine increment masses (optional)	2	2	40
	1	1	20
	1	0.5	10
	2	0.2	4
	1	0.1	2

# Specifications

## Model CPB3800HP

### Piston-cylinder system

**Measuring range <sup>1)</sup>** 1 ... 50 bar / 20 ... 2,600 bar

Required masses 107 kg

Smallest step <sup>2)</sup> (standard mass set) 0.5 bar / 10 bar

Nominal effective area of the piston 1/8 in<sup>2</sup> / 1/160 in<sup>2</sup>

**Measuring range <sup>1)</sup>** 10 ... 600 psi / 200 ... 40,000 psi or 10 ... 600 lb/in<sup>2</sup> / 200 ... 40,000 lb/in<sup>2</sup>

Required masses 119 kg

Smallest step <sup>2)</sup> (standard mass set) 5 psi / 100 psi or 5 lb/in<sup>2</sup> / 100 lb/in<sup>2</sup>

Nominal effective area of the piston 1/8 in<sup>2</sup> / 1/160 in<sup>2</sup>

### Accuracies

Standard <sup>3) 4)</sup> 0.025 % of reading

Premium <sup>3) 4)</sup> 0.007 % of reading

**Pressure transmission medium** Hydraulic fluid based on VG22 mineral oil (0.5 litre included in scope of delivery)

### Material

Piston Tungsten carbide / steel

Cylinder Steel / tungsten carbide

### Weight

Piston-cylinder system 2 kg

BAR mass set, box 1 43.3 kg

BAR mass set, box 2 29.7 kg

BAR mass set, box 3 29.4 kg

BAR mass set, box 4 29.4 kg

PSI or lb/in<sup>2</sup> mass set, box 1 40.5 kg

PSI or lb/in<sup>2</sup> mass set, box 2 33.6 kg

PSI or lb/in<sup>2</sup> mass set, box 3 33.6 kg

PSI or lb/in<sup>2</sup> mass set, box 4 31.6 kg

### Dimensions

Carrying case 1 for mass set (optional) 400 x 310 x 310 mm (W x D x H)

Carrying case 2 - 4 for mass set (optional) 215 x 310 x 310 mm (W x D x H)

- 1) Theoretical starting value; corresponds to the pressure value generated by the piston or the piston and its make-up weights (by their own weight). To optimise the operating characteristics more masses should be loaded.
- 2) The smallest pressure change value that can be achieved based on the standard mass set. To reduce this, a set of fine increment masses is also available.
- 3) The accuracy from 10 % of the measuring range is based on the measured value. In the lower part the accuracy is 0.025 % of reading.
- 4) Measurement uncertainty assuming reference conditions (ambient temperature 20 °C, atmospheric pressure 1,013 mbar, relative humidity 40 %). For operation without a CalibratorUnit, corrections must be made if required.

## Base

### Connections

Connection for piston-cylinder system	G ¾ B
Test item connection	G ½ union nut with metal cone, with three thread adapters as standard M16 x 1.5 / M20 x 1.5 and 9/16-18UNF

### Material

Wetted parts	Austenitic stainless steel, high tensile brass, nitrile rubber
Pressure transmission medium	Hydraulic fluid based on VG22 mineral oil (0.5 l included in scope of delivery) <sup>5)</sup>
Reservoir	170 cm <sup>3</sup>

### Weight

Base	13.5 kg
------	---------

### Permissible ambient conditions

Operating temperature	18 ... 28 °C
-----------------------	--------------

### Dimensions

Base	401 x 397 x 155 mm (W x D x H), for details, see technical drawings
------	---

5) Other pressure transmission media on request.

## CE conformity and certificates

### CE conformity

Pressure equipment directive	97/23/EC (module A)
------------------------------	---------------------

### Certificate

Calibration	Calibration certificate Option: UKAS calibration certificate
-------------	---

Approvals and certificates, see website

## Transport dimensions for complete instrument

The complete instrument, in its standard version and standard scope of delivery, is shipped on two pallets.

The dimensions are 1,200 x 800 x 500 mm and 800 x 600 x 500 mm.

The overall weight is dependent on the measuring range.

Version in bar	Weight in kg	
	net	gross
1 ... 50 / 20 ... 2,600 bar	169	207

Version in psi or lb/in <sup>2</sup>	Weight in kg	
	net	gross
10 ... 600 / 200 ... 40,000 psi or lb/in <sup>2</sup>	177	215

## Dimensions in mm

(without masses)

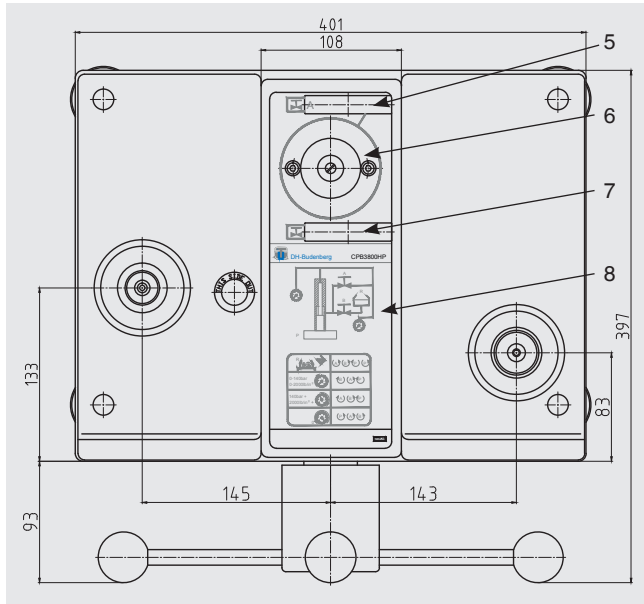
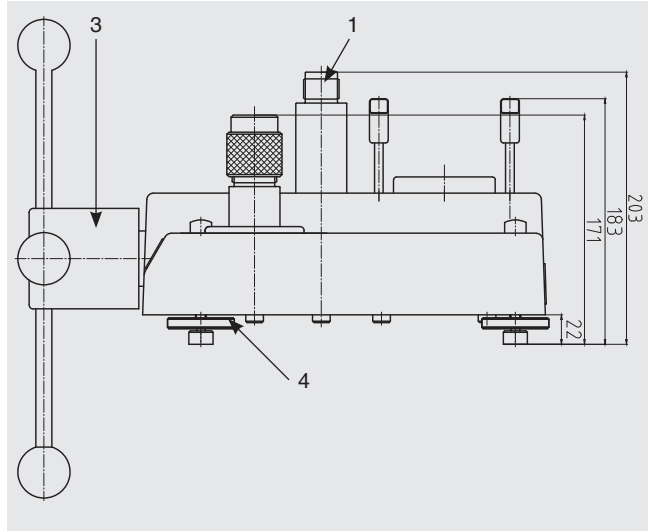
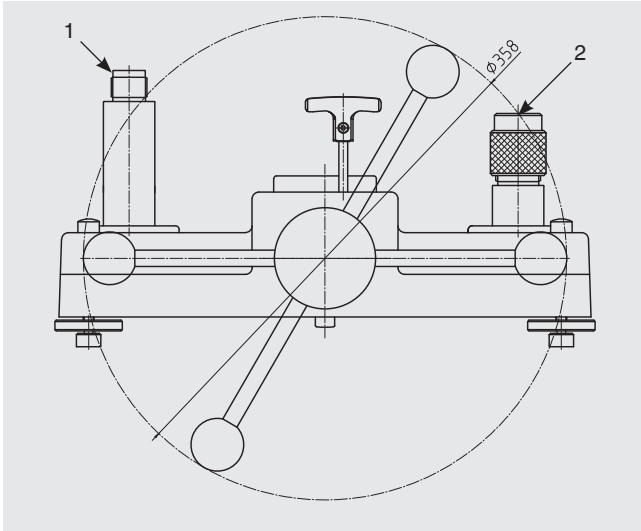

- (1) Piston connection
- (2) Test item connection
- (3) Dual-area spindle pump with star handle
- (4) Rotatable feet
- (5) High-pressure shut-off valve
- (6) Reservoir with plug screw
- (7) Low-pressure shut-off valve
- (8) Pressure generation control schematic

### Standard connection piston-cylinder system

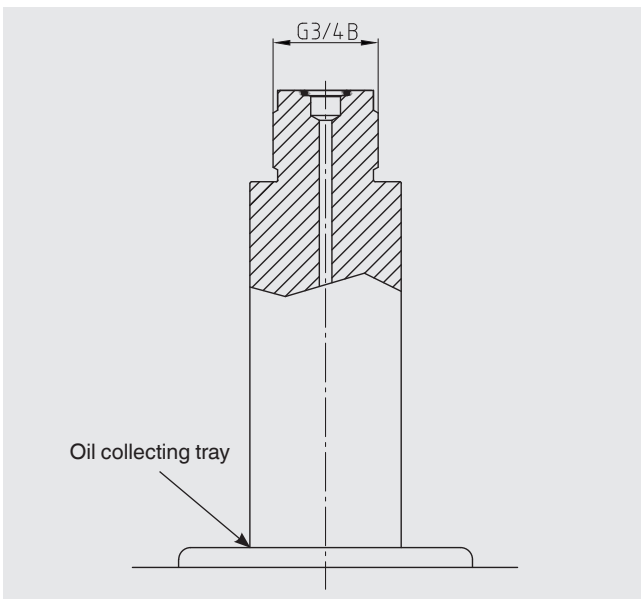

### Test item connection

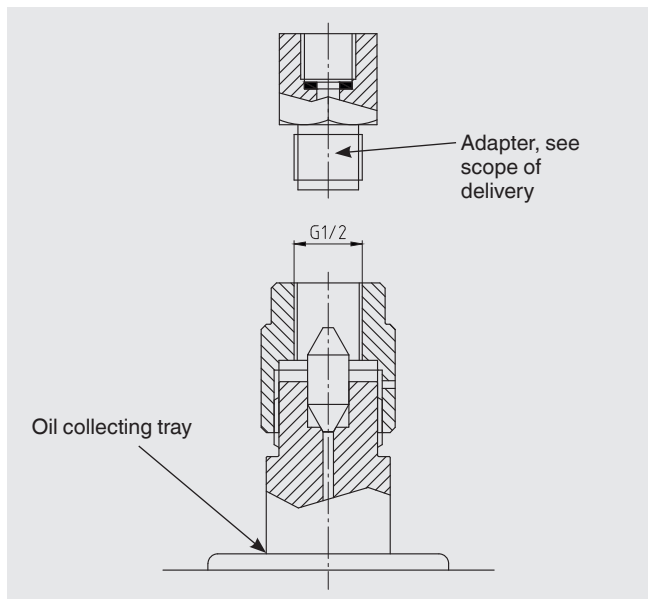

## CalibratorUnit model CPU6000

The models of the CPU6000 series are compact tools for use with a pressure balance (dead-weight tester). In particular when highly accurate measuring values, with measurement uncertainties of less than 0.025 %, are required, complicated mathematical calculations and corrections are necessary. With the CPU6000 in combination with the CPB-CAL (iPad® app) and/or WIKA-CAL (PC software) all critical ambient parameters can be registered and automatically corrected.

### The CPU6000 series is made up of three instruments

#### Weather station, model CPU6000-W

The CPU6000-W provides measured values such as atmospheric pressure, relative humidity and the ambient temperature of the laboratory environment.

#### Pressure balance sensor box, model CPU6000-S

The CPU6000-S measures the piston temperature and displays the floating position of the masses.

#### Digital multimeter, model CPU6000-M

The CPU6000-M fulfils the function of a digital multimeter and power supply unit when electronic pressure transmitters must be calibrated.

### Typical application

#### CPB-CAL iPad® app

The iPad® application calculates the mass loads for pressure balances (dead-weight testers) or the reference pressure while taking the measured parameters from the CPU6000 into account. The conversion can be carried out in all common pressure units. As an additional parameter, the local gravity can be given for location-independent measurements.

#### WIKA-CAL PC software - Weight calculator

With the demo version of the WIKA-CAL software and a CPB series pressure balance (dead-weight tester), the mass discs to be applied and the corresponding reference pressure can be determined. The pressure balance data (dead-weight tester data) can be entered into the database manually or imported automatically via an XML file available online. All ambient parameters and piston temperature can be entered manually into WIKA-CAL or can be measured automatically with the CPU6000 series, so that the highest accuracy can be achieved. WIKA-CAL demo version can be downloaded free of charge from the WIKA website.

Further specifications on the CPU6000 series can be found in data sheet CT 35.02.

For details of the WIKA-CAL calibration software see data sheet CT 95.10.



CPU6000 series and iPad® app CPB-CAL



Model CPU6000-W, CPU6000-S, CPB5800 and PC with WIKA-CAL software

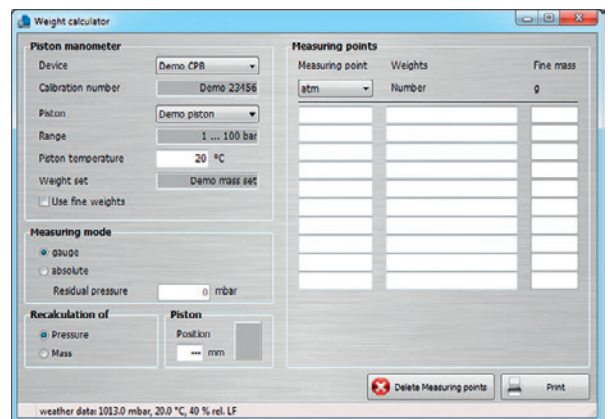

WIKA-CAL PC software - Weight calculator



## Further pressure balances (dead-weight testers) within our calibration technology programme

### Dead-weight tester, model CPB3800

#### Measuring ranges:

Hydraulic 1 ... 120 up to 10 ... 1,200 bar or  
10 ... 1,600 to 100 ... 16,000 psi,  
respectively

**Accuracy:** 0.05 % of reading  
0.025 % of reading (optional)

For specifications see data sheet CT 31.06



Dead-weight tester, model CPB3800

### Dead-weight tester, model CPB3500

#### Measuring ranges:

Pneumatic -0.015 ... -1 to 1 ... 120 bar or  
1 ... 100 to 10 ... 1.600 psi, respectively

**Accuracy:** 0.015 % of reading  
up to 0.006 % of reading (optional)

For specifications see data sheet CT 31.22



Dead-weight tester, model CPB3500

### Pressure balance, model CPB5800

#### Measuring ranges:

Hydraulic Single-piston measuring ranges:  
1 ... 120 to 2 ... 300 bar or  
10 ... 1,600 to 30 ... 4,000 psi, respectively

Dual-piston measuring ranges:  
1 ... 60 / 10 ... 700 bar to  
1 ... 60 / 20 ... 1,400 bar or  
10 ... 800 / 100 ... 10,000 psi to  
10 ... 800 / 200 ... 20,000 psi, respectively

**Accuracy:** 0.015 % of reading  
up to 0.006 % of reading (optional)

For specifications see data sheet CT 31.11



Pressure balance, model CPB5800

### Pressure balance for high pressure, model CPB5000HP

#### Measuring ranges:

Hydraulic 25 ... 2,500, 25 ... 4,000 or 25 ... 5,000 bar  
or  
350 ... 40,000, 350 ... 60,000 or  
350 ... 70,000 psi, respectively

**Accuracy:** 0.025 % of reading  
0.02 % of reading (optional)

For specifications see data sheet CT 31.51



Pressure balance for high pressure, model CPB5000HP



## Mass sets

### Set of trim masses M1 and F1

The masses included in the standard mass set are ideally suited for everyday use. If smaller intermediate values need to be generated, we recommend using a set of class M1 or F1 trim masses, with the following masses:

1 x 50 g, 2 x 20 g, 1 x 10 g, 1 x 5 g, 2 x 2 g, 1 x 1 g,  
1 x 500 mg, 2 x 200 mg, 1 x 100 mg, 1 x 50 mg, 2 x 20 mg,  
1 x 10 mg, 1 x 5 mg, 2 x 2 mg, 1 x 1 mg



Set of trim masses

## Scope of delivery

- Base
- Dual-area spindle pump for filling, pressure generation and fine pressure adjustment
- Piston connection
- Test item connection with G ½ union nut with metal cone and three thread adapters M16 x 1.5 / M20 x 1.5 and 9/16-18 UNF
- Piston-cylinder system
- Mass set manufactured to standard gravity (9.80665 m/s<sup>2</sup>)
- VG22 mineral oil (0.5 litre)
- Tool and maintenance set
- Operating instructions in German and English language
- Factory calibration certificate

## Options

- Systems with increased accuracy to 0.007 %
- Other pressure transmission media
- Other pressure units
- Mass set manufactured to local gravity
- Set of fine increment masses
- Storage case for the base, mass set and piston-cylinder system
- UKAS calibration certificate

## Ordering information

Model / Package / Accuracy / Gravity value g / Fine increment masses / Storage case / Calibration for dead-weight tester / Calibration for fine increment masses / Accessories

© 2015 WIKA Alexander Wiegand SE & Co. KG, all rights reserved.  
The specifications given in this document represent the state of engineering at the time of publishing.  
We reserve the right to make modifications to the specifications and materials.

WIKA data sheet CT 31.07 · 02/2015

Page 9 of 9

## Accessories

### Adapter

- Adapter for connection column, M16 x 1.5 male thread with sealing cone, mat.: hardened stainless steel
- Adapter for connection column, M20 x 1.5 male thread with sealing cone, mat.: hardened stainless steel
- Adapter for connection column, 9/16-18 UNF male thread with sealing cone, mat.: hardened stainless steel
- Adapter for connection column, G ½ female thread with O-ring, max. 1,600 bar, mat.: 1.4571

### Fine increment masses

- Fine increment masses in bar
- Fine increment masses in psi

### Fluids

- Hydraulic fluid based on VG22 mineral oil in plastic bottle, content 0.5 litre

### Storage

- Storage box for instrument base (and CPB3800HP piston-cylinder system)
- Four wooden boxes for mass set

### Tools

- Sealing and maintenance set for instrument base
- Tool set consisting of open-ended spanner, replacement seals, pointer remover and pointer punch